

**Základné pohyby pri rezaní**

a - pozdĺžne sústruženie, b - hobľovanie, c - čelné sústruženie; 1 - obrábaná plocha, 2 - rezná plocha, 3 - obrobená plocha

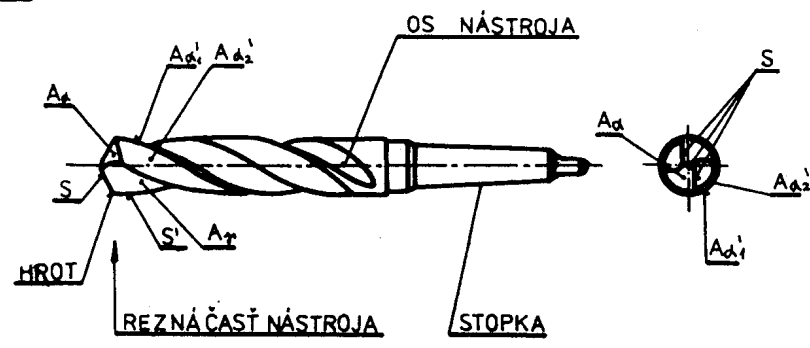

**Tvar hrotu rezného klina**

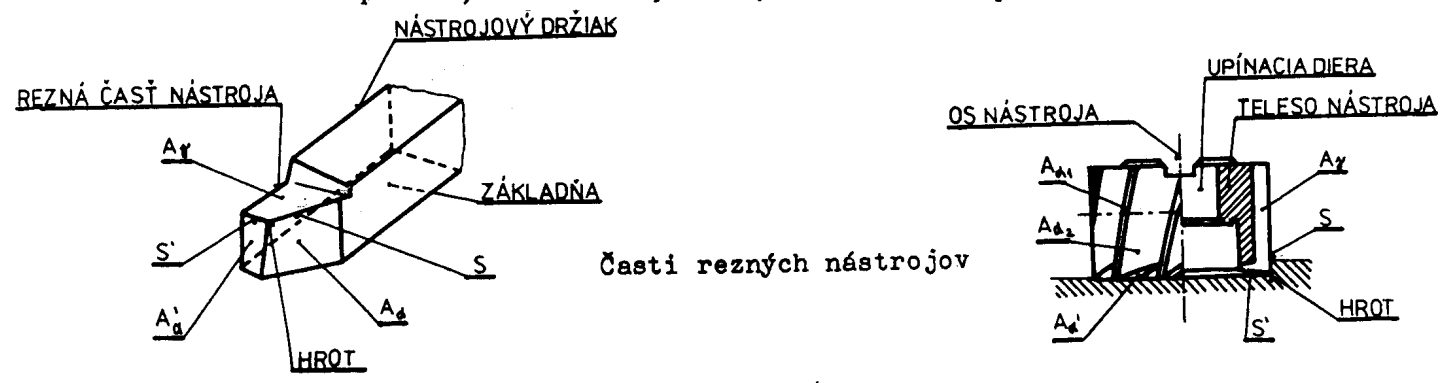
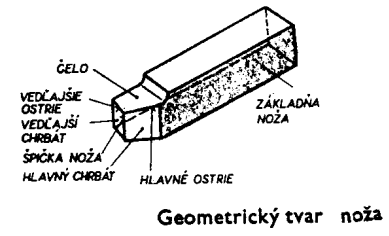
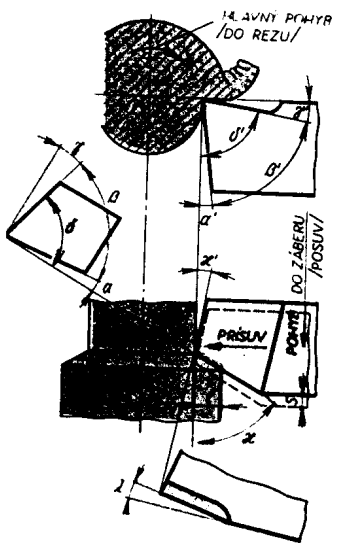
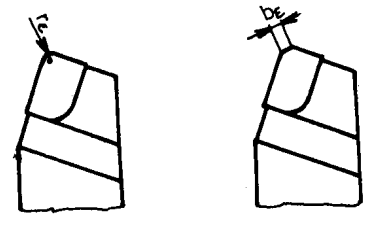

**Geometrický tvar noža**

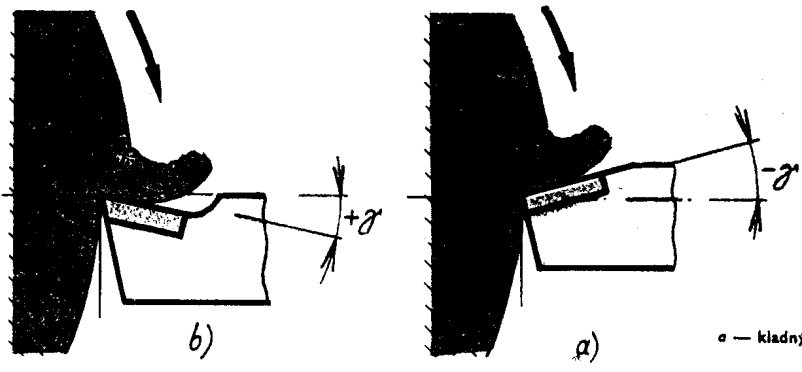

**Obrábanie sústružníckym nožom**

$\alpha$  — uhol chrbtu,  $\beta$  — uhol rezného klina,  $\gamma$  — uhol čela,  $\sigma$  — uhol rezu,  $\lambda$  — uhol sklonu reznej hrany,  $\kappa$  — uhol nastavenia noža,  $s$  — posuv na otáčku,  $t$  — hĺbka triesky

**Nôž s uhlom čela**  
a — kladným, b — záporným